

Values for Discrete Component Coupler

Chris Haji-Michael

<http://www.sunshadow.co.uk/chris.htm>

This page calculates the component vales for a 90 degree discrete component directional coupler. The circuit is shown below. The equations are from "Improved Planar Spiral Transformer Theory..." IEEE MTT, April 1997, p543 and from hand notes from Ole Kiel Jensen at Aalborg University.

Freq := $1 \cdot 10^9$ Hz

c := -10, -12.. -20 Coupling in dB from port 2 to 3.

Zo := 50ohm

nH := $1 \cdot 10^{-9}$ H

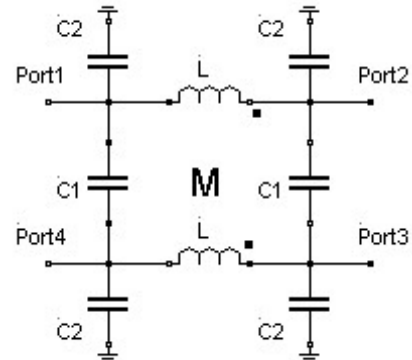

$$Zoe(c) := Zo \cdot \left[\frac{\left(1 + 10^{\frac{c}{20}}\right)^{0.5}}{\left(1 - 10^{\frac{c}{20}}\right)} \right]$$

$$Zoo(c) := Zo \cdot \left[\frac{\left(1 - 10^{\frac{c}{20}}\right)^{0.5}}{\left(1 + 10^{\frac{c}{20}}\right)} \right]$$

$$C1(c) := \left(\frac{1}{Zoo(c)} - \frac{1}{Zoe(c)} \right) \cdot \frac{1}{4 \cdot \pi \cdot \text{Freq}}$$

$$C2(c) := \frac{1}{Zoe(c)} \cdot \frac{1}{2 \cdot \pi \cdot \text{Freq}}$$

$$L(c) := (Zoo(c) + Zoe(c)) \cdot \frac{1}{4 \cdot \pi \cdot \text{Freq}}$$

$$M(c) := \frac{(Zoe(c) - Zoo(c)) \cdot 1}{2 \cdot \pi \cdot \text{Freq}}$$

Mutual Inductance

$$k(c) := \frac{Zoe(c) - Zoo(c)}{Zoe(c) + Zoo(c)}$$

Inductor Coupling

c =	Zoo(c) =	ohm	Zoe(c) =	ohm
-10	36.038		69.371	
-12	38.681		64.632	
-14	40.845		61.207	
-16	42.614		58.666	
-18	44.056		56.746	
-20	45.227		55.277	

c =	C1(c) =	pF	C2(c) =	pF	L(c) =	nH	k(c) =	M(c) =	nH
-10	1.061		2.294		8.388		0.316	5.31	
-12	0.826		2.462		8.221		0.251	4.13	
-14	0.648		2.600		8.121		0.200	3.24	
-16	0.511		2.713		8.060		0.158	2.55	
-18	0.404		2.805		8.022		0.126	2.02	
-20	0.320		2.879		7.998		0.100	1.60	