

Values for Discrete Component Branch Line Coupler (Type-1)

Chris Haji-Michael

<http://www.sunshadow.co.uk/chris.htm>

This page calculates the circuit values for a branch line coupler. The equations are from "Practical Microstrip Circuit Design", Trinogga, Kaizhou, Hunter, P363. In this coupler the wanted power goes from port 1 to port 3; coupled power goes to port 2.

Freq := $2.0 \cdot 10^9$ Hz

c := -2, -4..-16 Coupling Ratio (power to port 2 wrt 3)

Zo := 50ohm

nH := $1 \cdot 10^{-9}$ H

$k2(c) := 10^{\left(\frac{c}{10}\right)}$ $k3(c) := 1 - k2(c)$ $k(c) := \frac{k2(c)}{k3(c)}$

$Z1(c) := Zo \cdot k(c)^{0.5}$ $Z2(c) := \left[\frac{k(c)}{k(c) + 1} \right]^{0.5} Zo$

LosstoP3(c) := $10 \cdot \log(k3(c))$

$L1(c) := Z1(c) \frac{1}{2 \cdot \pi \cdot \text{Freq}}$

$L2(c) := Z2(c) \frac{1}{2 \cdot \pi \cdot \text{Freq}}$

$CL1(c) := \frac{1}{Z1(c)} \cdot \frac{1}{2 \cdot \pi \cdot \text{Freq}}$

$CL2(c) := \frac{1}{Z2(c)} \cdot \frac{1}{2 \cdot \pi \cdot \text{Freq}}$

C(c) := CL1(c) + CL2(c)

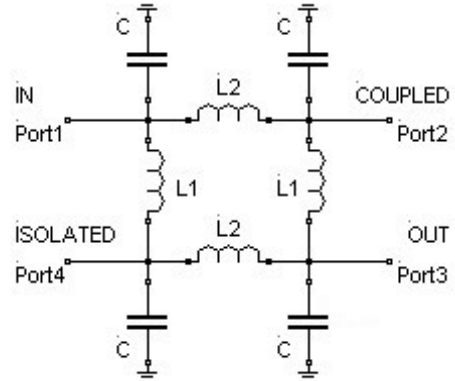

c =	Z1(c) =	Z2(c) =
-2	65.38 ohm	39.72 ohm
-4	40.66	31.55
-6	28.96	25.06
-8	21.70	19.91
-10	16.67	15.81
-12	12.98	12.56
-14	10.18	9.98
-16	8.03	7.92

Z1 = port 1 to 4 (shunt)
Z2 = port 2 to 3 (series)

c =	L1(c) =	L2(c) =	C(c) =	LosstoP3(c) =
-2	5.20 nH	3.16 nH	3.22 pF	-4.329
-4	3.24	2.51	4.48	-2.205
-6	2.30	1.99	5.92	-1.256
-8	1.73	1.58	7.67	-0.749
-10	1.33	1.26	9.81	-0.458
-12	1.03	1.00	12.47	-0.283
-14	0.81	0.79	15.79	-0.176
-16	0.64	0.63	19.96	-0.110